

固定式片開き分岐

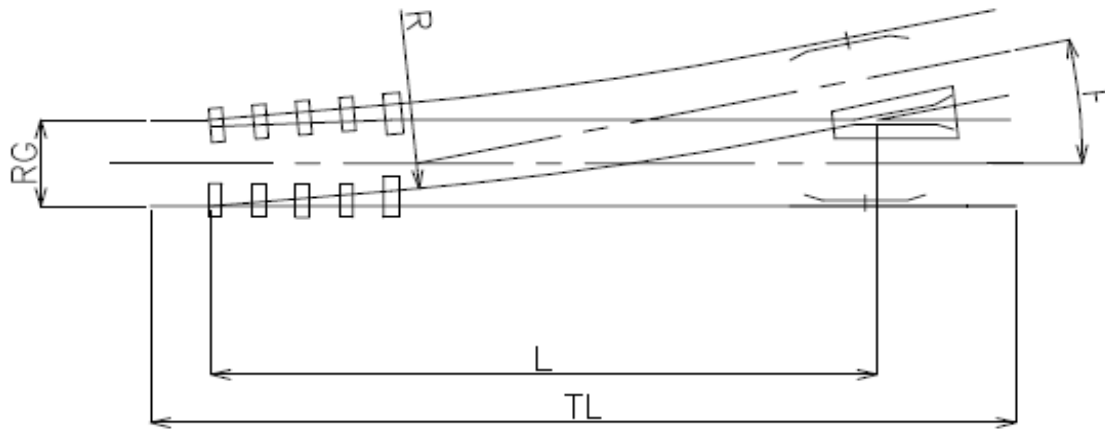

レール(Kg)	クロスNo	F	RG(mm)	R(mm)	L(mm)	TL(mm)
15	4	14° 18'	610	12,000	4,321	5,721
			762	17,306	5,265	6,665
	5	11° 26'	610	20,752	4,888	6,313
			762			
22	5	11° 26'	610	20,000	4,548	6,248
			762	30,678	5,520	7,220
			914	29,990	7,603	9,303
	6	9° 32'	762	34,032	7,172	9,072
914			48,012	8,556	10,946	
30	4	14° 18'	914	20,437	6,593	8,293
			762	25,145	6,403	8,303
	5	11° 26'	914	30,000	7,603	9,503
			762	29,320	7,923	10,000
			914	34,660	9,045	11,122

固定式両開き(Y型)分岐器

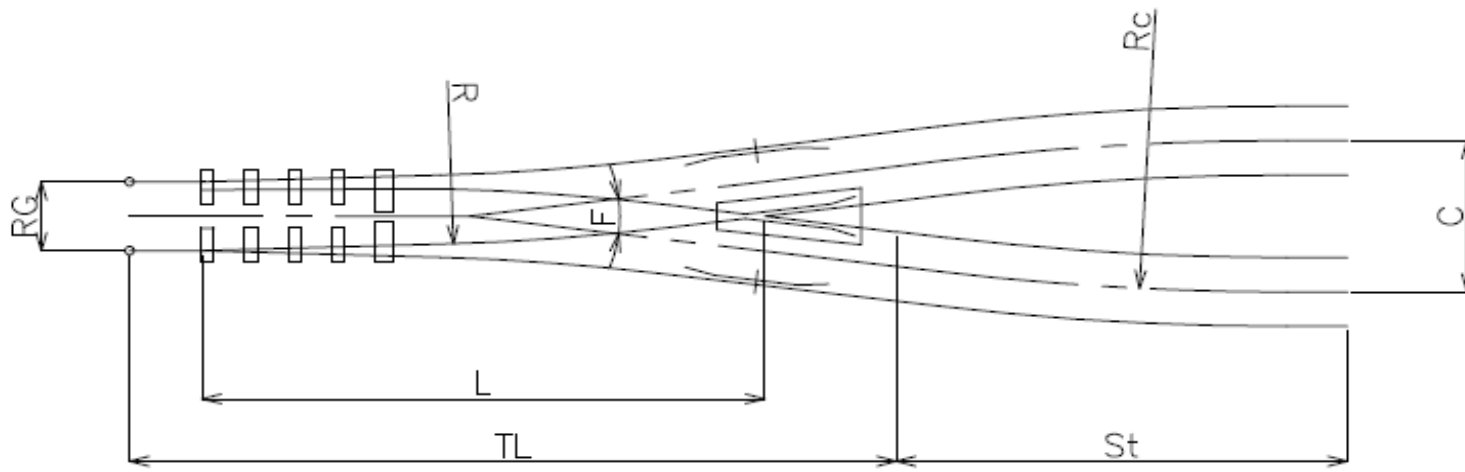

レール(Kg)	クロスNo	F	RG(mm)	C(mm)	R(mm)	Rc(mm)	L(mm)	TL(mm)	St(mm)
15	3.5	16° 20'	610	1,306	17,060	17,060	3,869	5,359	2,909
	4	14° 18'	610	1,306	25,211	25,211	4,215	5,608	3,918
			762	1,610	33,255		5,399	6,792	
22	4	14° 18'	610	1,322	20,197	20,197	4,067	5,678	3,450
			762	1,626	33,103	29,619	4,843	6,454	4,183
			914	1,930	34,740		6,872	8,483	
30	4	14° 18'	762	1,645	28,173	28,173	5,954	7,645	4,641
			914	1,949	30,053	30,000	6,628	8,220	5,451
	5	11° 26'	762	1,645	40,381		6,401	8,295	
			914	1,949	52,520		7,598	9,492	
	6	9° 32'	762	1,645	31,660		7,360	9,432	
			914	1,949	31,660		8,271	10,343	

固定式亘線(N型)分岐

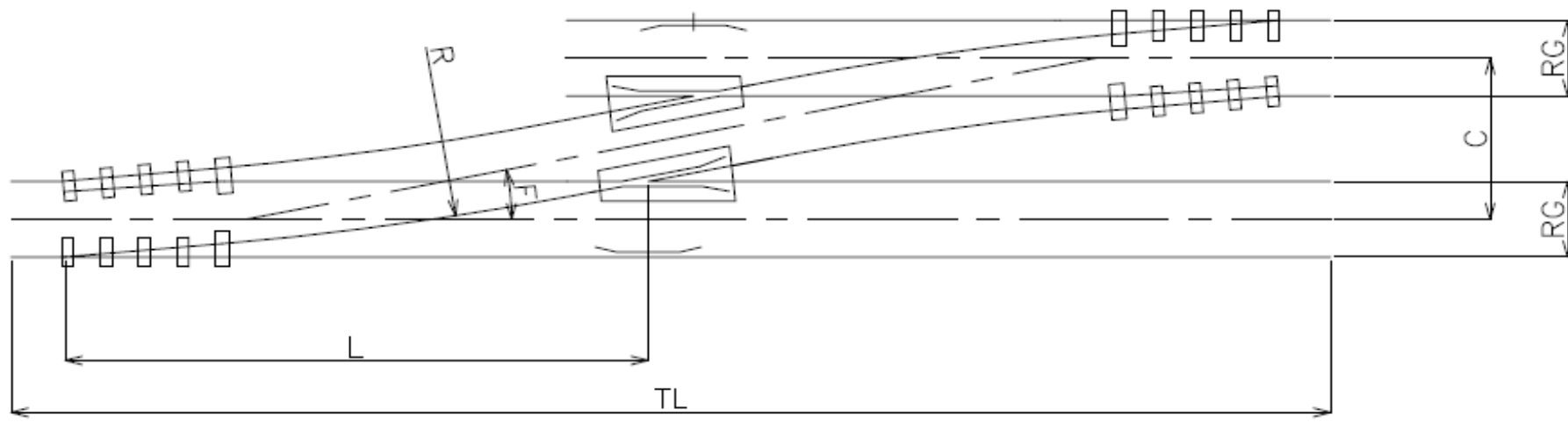

レール(Kg)	クロスNo	F	RG(mm)	C(mm)	R(mm)	L(mm)	TL(mm)
15	5	11° 26'	610	1,306	20,752	4,888	11,140
			762	1,610			
22	5	11° 26'	610	1,322	20,000	4,548	10,539
			762	1,626	30,678	5,520	12,468
			914	1,930			
	6	9° 32'	762	1,626	34,032	7,172	15,888
30	5	11° 26'	762	1,645	25,145	6,403	14,528
			914	1,949	30,000	7,603	16,913
	6	9° 32'	762	1,645	29,318	7,923	17,655
			914	1,949	34,660	9,045	19,886

固定式交叉亘線(X型)分岐

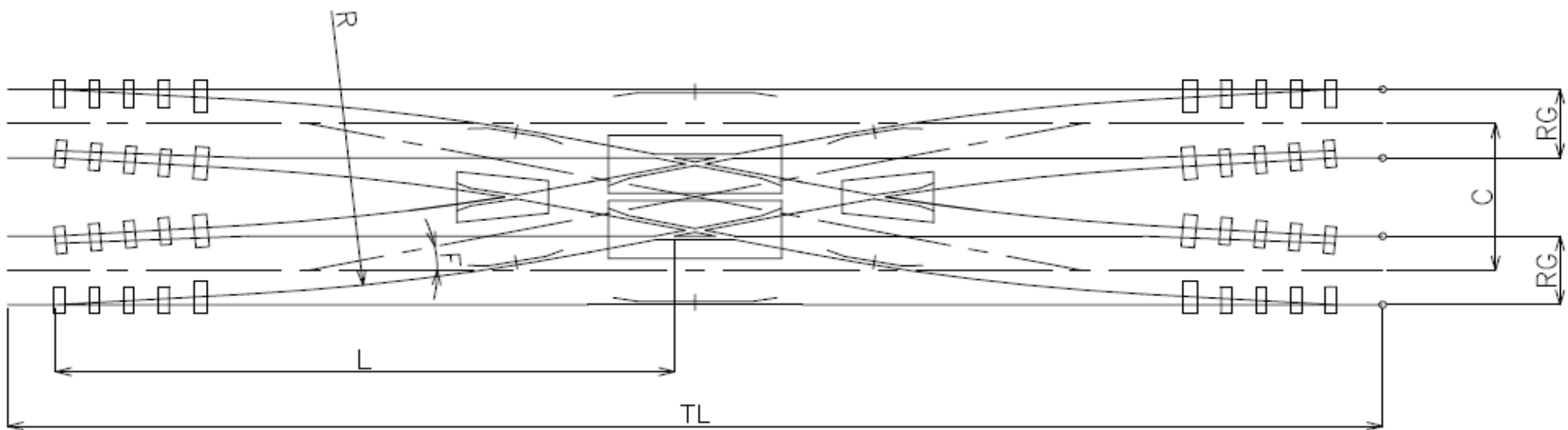

レール(Kg)	クロスNo	F	RG(mm)	C(mm)	R(mm)	L(mm)	TL(mm)
15	5	11° 26'	610	1,306			
22	5	11° 26'	762	1,626	25,695	6,430	14,288
	6	9° 32'	610	1,322	28,415	5,745	13,047
762			1,626	39,669	7,172	15,888	
30	5	11° 26'	762	1,645	25,387	6,415	14,552
			914	1,949	30,000	7,603	16,913
	6	9° 32'	762	1,645	32,570	7,910	17,624
914			1,949	34,660	9,045	19,888	